

Level and pressure instrumentation for wastewater treatment

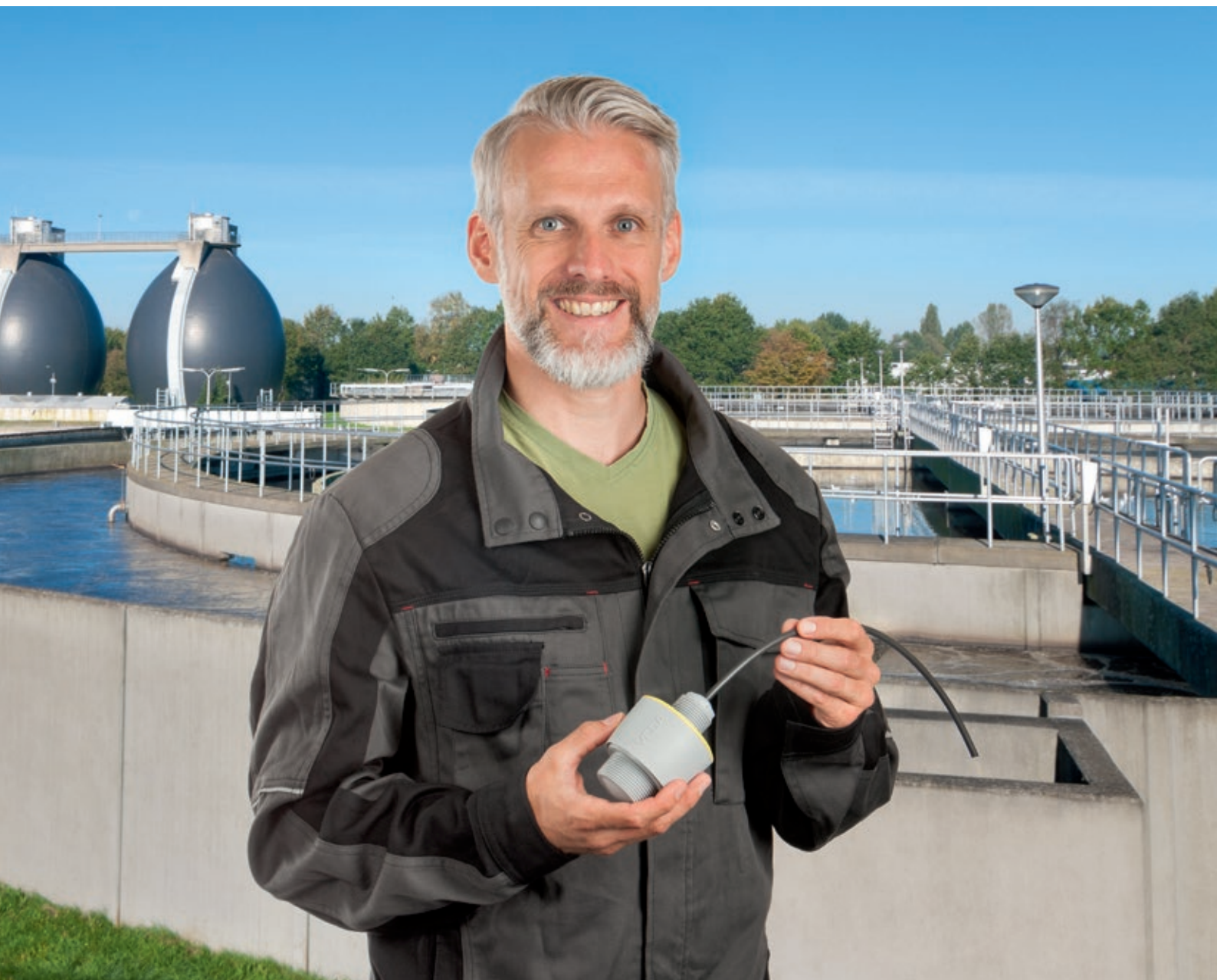

Application examples and products



Instrumentation for wastewater treatment

This brochure presents examples of applied level and pressure measurement technology. Here, you'll learn which sensors fit which measuring tasks.

2 Combined sewer overflow	Level measurement	13 Precipitant and chemicals station	Level measurement and point level detection
1 Sewer network	Gauge measurement	17 Digester	Level measurement and point level detection
5 Pumping station	Level measurement	19 Biogas storage facility	Volume and pressure monitoring
7 Inlet channel	Flow rate measurement	23 Sludge granulate silo	Level measurement
9 Coarse and fine screens	Gauge measurement	30 Container	Level measurement
10 Grit trap	Point level detection	25 Pump room	Pressure measurement and point level detection





More applications can be found at

www.vega.com/wastewater



3 Stormwater retention basin	Level measurement	16 Sludge thickener tank	Level measurement
4 Vacuum sewerage system	Level measurement	18 Gas pipeline	Quantity measurement
6 Sewage screw lifting station	Level measurement	20 Sludge storage tank	Level measurement
8 Sludge receiving station	Level measurement	21 Sludge dewatering	Point level detection
11 Grit washer	Point level measurement	22 Sludge drying	Density measurement
12 Mixing and equalization ponds	Gauge measurement	24 Process water tank	Level measurement
14 Lime silo	Level measurement	26 Gauge station	Gauge measurement
15 Conditioning	Level measurement	28 Fuel tank	Level measurement
		29 Receiving water	Level measurement

All sensors at a glance

Continuous level measurement

Instrument type		Measuring range	Process fitting	Process temperature	Process pressure
VEGAPULS C 11 Wired radar sensor for continuous level measurement		up to 8 m	Thread G1½, 1½ NPT	-40 ... +60 °C	-1 ... +3 bar (-100 ... +300 kPa)
VEGAPULS C 21/22 Wired radar sensor for continuous level measurement		up to 15 m	Thread G1½, 1½ NPT	-40 ... +80 °C	-1 ... +3 bar (-100 ... +300 kPa)
VEGAPULS C 23 Wired radar sensor for continuous level measurement		up to 30 m	-	-40 ... +80 °C	-1 ... +3 bar (-100 ... +300 kPa)
VEGAPULS 21 Compact radar sensor for continuous level measurement		up to 15 m	Thread G1½, 1½ NPT	-40 ... +80 °C	-1 ... +3 bar (-100 ... +300 kPa)
VEGAPULS 64 Radar sensor for continuous level measurement of liquids		up to 30 m	Mounting strap, thread from G¾, ¾ NPT, flanges from DN 50, 2", compression flanges from DN 80, 3"	-196 ... +200 °C	-1 ... +25 bar (-100 ... +2500 kPa)



Point level detection

Instrument type		Measuring range	Process fitting	Process temperature	Process pressure
VEGACAP 64 Capacitive rod probe for point level detection		Fully insulated rod up to 6 m	Thread G¾, ¾ NPT Flanges from DN 25, 1"	-50 ... +200 °C	-1 ... +64 bar (-100 ... +6400 kPa)
VEGASWING 63 Vibrating level switch with tube extension for liquids		up to 6 m	Thread from G¾, ¾ NPT Flanges from DN 25, 1"	-50 ... +250 °C	-1 ... +64 bar (-100 ... +6400 kPa)
VEGAVIB 62 Vibrating level switch with suspension cable for granular bulk solids		Bulk solids from 20 g/l	Thread from G1, 1 NPT Flanges from DN 32, 1½"	-10 ... +150 °C	-1 ... +6 bar (-100 ... +600 kPa)

Pressure measurement

Instrument type		Measuring range	Process fitting	Process temperature	Process pressure
VEGABAR 82 Pressure transmitter with ceramic measuring cell		0.2 % 0.1 % 0.05 %	Thread G½, ½ NPT Flanges from DN 15, 1½"	-40 ... +150 °C	-1 ... +100 bar (-100 ... +10000 kPa)

Signal processing

Instrument type		Hysteresis	Input	Output	Operating voltage
VEGAMET 841/842 Robust controller and display instrument for level sensors		adjustable	VEGAMET 841: 1x 4 ... 20 mA sensor input VEGAMET 842: 2x 4 ... 20 mA sensor input	1/2x 0/4 ... 20 mA current output 3x operating relay 1x fail safe relay (instead of an operating relay)	24 ... 65 V DC 100 ... 230 V AC, 50/60Hz
VEGAMET 861 Robust controller and display instrument for level sensors		adjustable	1x 4 ... 20 mA/HART sensor input 2x digital input	1/3x 0/4 ... 20 mA current output 4/6x operating relay 1x fail safe relay (instead of an operating relay)	24 ... 65 V DC 100 ... 230 V AC, 50/60Hz



Wastewater treatment



Accurate, service-proven instrumentation

VEGA is an experienced supplier of instrumentation for sewage treatment plants. The company has been delivering level and pressure sensors to wastewater plants around the world for decades.

VEGA instrumentation provides accurate measurement data as a basis for automatic control of the various process steps. All sensors use state-of-the-art technology and are optimised and certified for deployment in wastewater treatment facilities.



Reasonable price

Quality pays off: these durable sensors reduce maintenance and operating costs.

Fast delivery

Whether initial delivery or repair: VEGA instruments arrive at your facility within a few days. This considerably reduces stocking costs.



Simple integration

VEGA sensors can be easily integrated into existing systems. Fast mounting and setup make installation easy.



Combined Sewer Overflow (CSO)

Reliable

High operational reliability even when subjected to inundation

Cost effective

Reliable measurement and maintenance-free operation

User friendly

Simple setup and adjustment

Level measurement in the stormwater overflow chamber

Large Combined Sewer Overflows (CSOs) protect the wastewater treatment plant from a capacity overload during heavy rain. The precipitation is temporarily stored and then delivered to the treatment plant at a reduced rate. If the stormwater basin cannot hold the accumulating quantities of water, part of it is discharged. Due to legal requirements, such operational events and discharged water quantities must be measured and documented. A level sensor provides the required measurement data.



VEGAPULS C 22

Event duration and stormwater retention monitoring using radar level sensor

- Reliable overflow detection without requiring a fouling-prone submergence shield
- Radar based sensor enables accurate monitoring of level and discharge quantity
- Reliable overflow detection without additional, contamination-causing brackets
- Secure, user-friendly wireless operation via Bluetooth with smartphone, tablet or PC

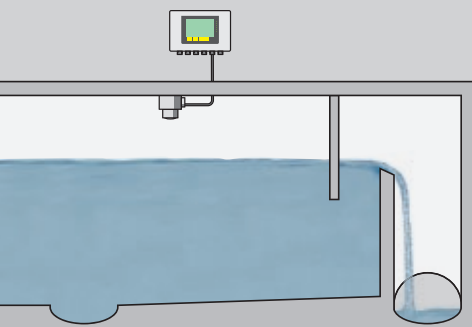

VEGAMET 861

Controller and display instrument for level and flow volume computation

- Clearly arranged display for indication of retained and discharged quantities
- Highly accurate calculation of the discharge volume
- Large measurement data memory with micro SD card



Sewer network

Reliable

Reliable function even when subjected to flooding

Cost effective

Maintenance-free operation

User friendly

Simple installation and setup

Level measurement in a sewer network

Wastewater from households and industrial operations is carried through a sewerage system to the clarification plant. In large sewer systems, the water levels are monitored at key points in the network. Level measurement in the sewer allows an accurate assessment of the degree of utilization of the conduit system.



VEGAPULS C 21

Non-contact radar level measurement in the sewage inlet channel

- Reliable overflow detection without requiring a fouling-prone submergence shield
- Highly resistant materials ensure a long service life and maintenance-free operation
- Secure, user-friendly wireless operation via Bluetooth with smartphone, tablet or PC

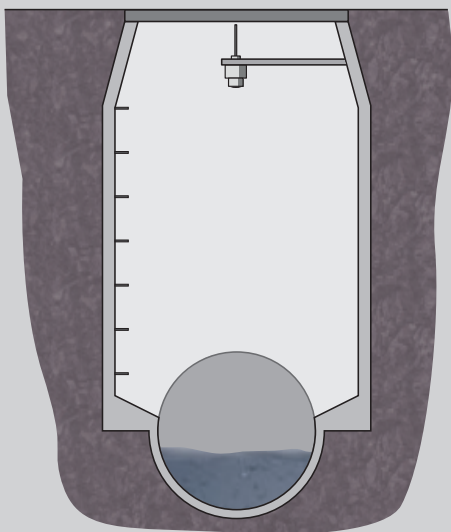



Pumping station

Reliable

Reliable measurement of the level

Cost effective

Pump switching ensures optimal operating times

User friendly

Maintenance-free, trouble-free operation

Level control in a pumping station

Wastewater from households and businesses, together with surface water, is carried to the wastewater treatment plant via an extensive sewer network. If the natural gradient is not steep enough, numerous pumping stations are required to create a sufficient height difference. The level measurement in the inlet shaft is used for cost-effective control of the pumps.



VEGAPULS C 11

Non-contact level measurement with radar in the inlet shaft

- Exact measuring results unaffected by internal fixtures and foaming
- High plant availability thanks to wear and maintenance free measurement
- Highly corrosion resistant materials ensure a long service life
- Secure, user-friendly wireless operation via Bluetooth with smartphone, tablet or PC

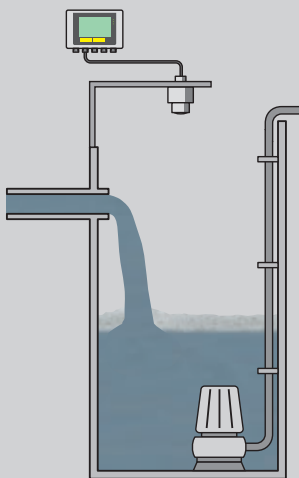

VEGAMET 841

Controller and display instrument for pump control

- Universal controller for simple pump control
- Fast setup and commissioning thanks to simple menu navigation and application wizards



Inlet channel

Reliable

High measurement accuracy,
independent of temperature influence

Cost effective

Low maintenance requirements

User friendly

Flow-proportional output signal

Flow-rate measurement in open channels

Sewage and rainwater are often transported to the treatment plant in open collection channels or flumes. The flow rate is measured at various points in these channels. Measurement of the water flow at the inlet and outlet of the treatment plant is the basis for the calculation of tariffs and operating costs.



VEGAPULS C 21

Flow measurement of the wastewater inlet with radar
in an open channel

- High plant availability thanks to wear and maintenance free measurement
- Exact measuring results unaffected by ambient conditions
- Sensor-integrated flow characteristic curves make it also possible to have a direct flow-proportional output signal
- Secure wireless operation through Bluetooth with smartphone, tablet or PC



VEGAMET 861

Flow computation, control and display for open channel
flow measurement structures

- Highly accurate calculation of the flow rate
- Clear, simple display of flow rate and total flow volume
- Fast setup and commissioning thanks to simple menu navigation and application wizards

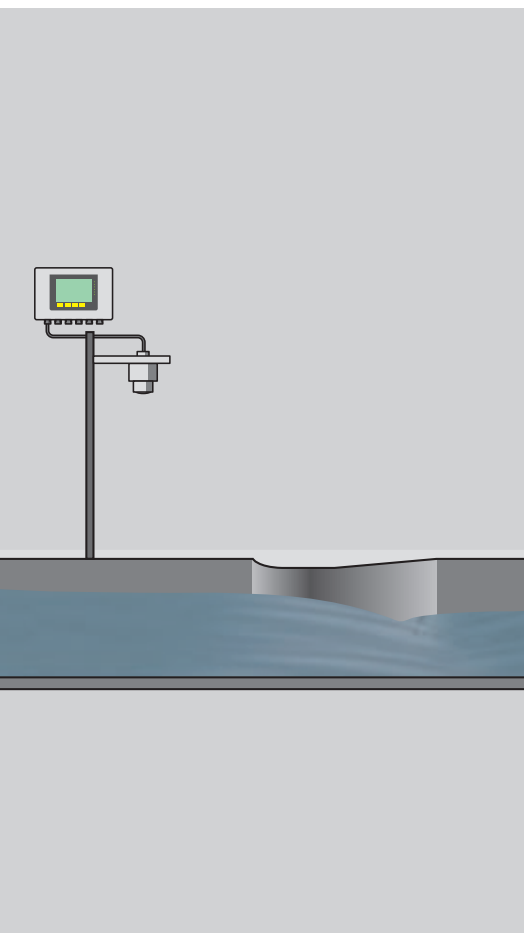



Coarse and fine screens

Reliable

Reliable control of screen cleaning

Cost effective

Non-contact and wear-free measurement

User friendly

Maintenance-free operation of the system

Differential water level measurement for control of screen raking

Mechanical cleaning removes entrained floating matter with screens or sieves. This protects the downstream process stages from buildup, clogging and abrasion. Solids with diameters greater than 25 mm are trapped in the coarse screens, compressed in a press and then disposed of. Finer secondary screens remove smaller residual materials. Measurement of the difference in water level between the front and the back of the screen determines the degree of contamination and initiates the cleaning of the screen when necessary.



VEGAPULS C 21

The radar sensors measure the water level difference between the front and back of the rake screen

- Exact measuring results unaffected by ambient conditions
- High plant availability thanks to wear and maintenance free measurement
- Secure wireless operation via Bluetooth with smartphone, tablet or PC



VEGAMET 842

Controller for measured value processing and display

- Universal controller for two analogue sensors for differential measurement
- Analogue outputs for connection to process control systems
- Fast setup via simple menu navigation and application wizards

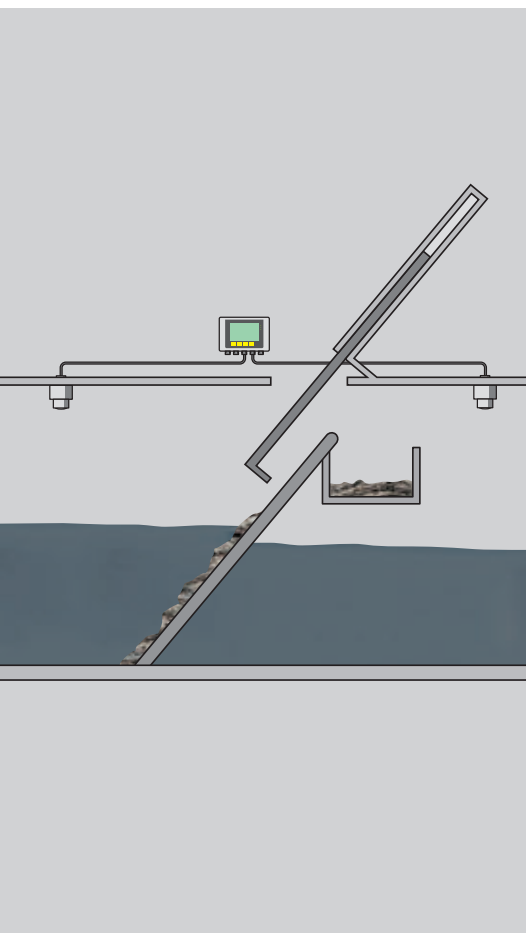



Grit trap

Reliable

Reliable control of the cleaning cycle in sand traps

Cost effective

Targeted cleaning depending on the amount of sand deposits

User friendly

Simple installation and maintenance-free operation

Point level detection in a grit trap

Through circulation and aeration of the wastewater, mineral substances such as grit and sand settle to the bottom of the settling basin. Point level detection of settled sand under water prevents equipment malfunction and damage and controls the cleaning cycle in the grit trap.



VEGA VIB 62

Level detection of settled grit under water

- Reliable function through product-independent switching point
- Wear and maintenance free operation
- Freely moving sensor element and highly durable suspension cable



VEGA TOR 121

Single channel controller for level detection

- Comprehensive monitoring detects short-circuit and line break of the measuring cable and interferences in the sensor
- Simple and comfortable SIL and WHG function test by means of test key
- Simple installation through carrier rail mounting as well as detachable, coded terminals

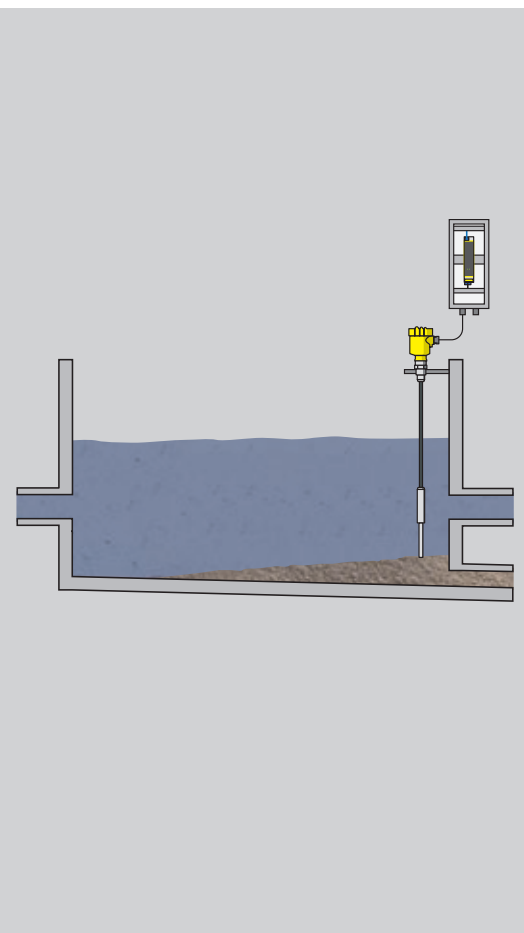



Chemical tanks

Reliable

Reliable measurement right through tank top

Cost effective

Tank is less expensive because it needs fewer process fittings

User friendly

Simple installation

Level measurement and point level detection in the chemical tank

Through the addition of chemicals, phosphates in the wastewater are precipitated out, for example in primary sedimentation, in aeration systems or in special precipitation and secondary clarifiers. Precipitants like ferric chloride bind the phosphate chemically and deposit it in the sludge. In the storage tanks for these chemicals, a level measurement and point level detection system is deployed for continuous inventory control and optimal dosage.



VEGAPULS 21

Continuous level measurement with radar for inventory monitoring of treatment chemicals

- Maintenance-free operation through non-contact 80 GHz radar technology
- Exact measuring results independent of product, process and ambient conditions
- Highly corrosion resistant materials ensure a long service life
- On plastic containers, measurement from the outside is possible, through the vessel top

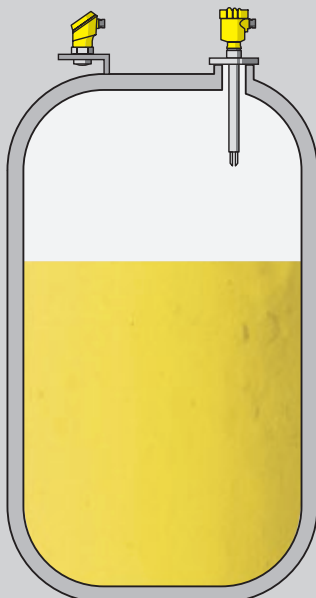

VEGASWING 63

Backup point level detection system to avoid overfilling the tank with media hazardous to water

- A choice of highly chemically resistant materials and coatings
- Universally applicable
- Adjustment and maintenance free operation



Digester

Reliable

Reliable level measurement and protection against foam overflow

Cost effective

Continuous, maintenance-free operation of the digester

User friendly

Low maintenance costs and reliable gas production

Level measurement and point level detection of foam in the digester

The organic components of sewage sludge are decomposed under anaerobic conditions in heated, closed digestion tanks. In the process, combustible gases such as methane are released from the sludge. These are collected in a biogas tank and then converted into electricity and heat in cogeneration (CHP) plants. A level sensor controls the filling of the digester. To ensure that no foam gets into the gas system along with the collected gas, a point level sensor is used for monitoring.



VEGAPULS 64

Level measurement with radar for control of the filling process

- Maintenance-free operation through non-contact measurement
- Accurate and reproducible measurement data, independent of gas concentration and pressure fluctuations
- Reliable measurement, even with foam and density changes
- Wireless operation via Bluetooth with smartphone, tablet or PC



VEGACAP 64

Detection of the conductive foam prevents it from entering the gas facility

- Reliable foam detection, even with different foam consistencies
- Unaffected by contamination and buildup
- Simple mounting and setup





Biogas storage facility

Reliable

High measurement certainty without mechanical wear

Cost effective

Optimal information on the available gas quantity

User friendly

Maintenance-free, reliable operation of the facility

Volume and pressure monitoring in the biogas storage facility

The methane gas extracted from the digestion tank is temporarily stored in a gas reservoir. Depending on the design of the gas storage facility, either a flexible diaphragm of plastic or a floating roof is used for volume equalization. The gas volume and gas pressure are measured continuously to ensure reliable and safe operation.

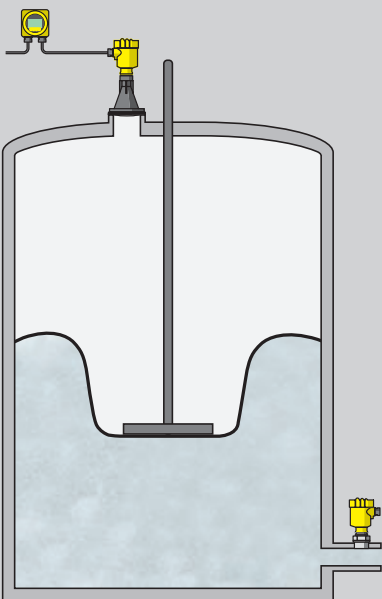

VEGAPULS 64

Continuous level measurement with radar for permanent gas volume measurement

- Reliable, maintenance-free measurement
- Independent of environmental influences
- Easy integration into existing gas storage facilities
- Wireless operation via Bluetooth with smartphone, tablet or PC



VEGABAR 82

Monitoring of the gas pressure in the gas reservoir

- High measuring accuracy through use of finely graduated measuring cells
- Robust sensor construction for high availability
- Long-term stability of the ceramic measuring cell ensures maintenance-free operation



VEGADIS 82

External measured value display in field housing

- Easy-to-read display with plain text and graphics
- Robust housing designed for the harsh conditions in the field



Sludge granulate silo

Reliable

Optimum protection against overfilling

Cost effective

Continuous measurement allows maximum use of container

User friendly

Reliable, maintenance-free operation

Level measurement and point level detection in the sludge granulate silo

After thermal drying, the sludge is stored in silos for further use. The granulated product is deposited in landfills, used in agriculture or burned for energy generation. The level measurement and point level detection ensure that the container volume is optimally utilized.

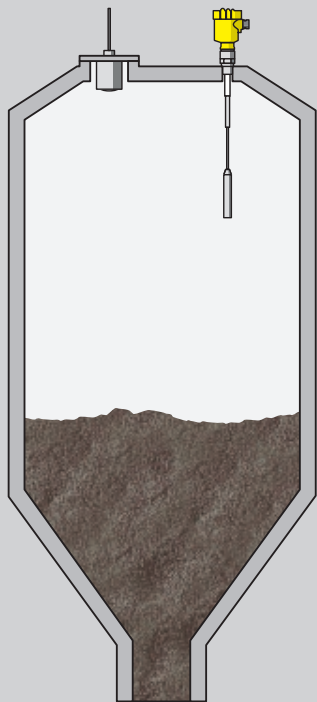

VEGAPULS C 23

Continuous radar level measurement of the sludge granulate silo

- Simple mounting and setup
- Unaffected by dust generation
- Maintenance free thanks to contactless measurement
- Wireless operation via Bluetooth with smartphone, tablet or PC



VEGACAP 65

Capacitive point level detection for full alarm during filling

- Dependable full alarm during filling
- Robust mechanical design of sensor ensures a long service life
- Cable can be shortened for easy adaptation to local conditions



Container

Reliable

Reliable content measurement in the screened waste container

Cost effective

Maintenance-free, non-contact measurement

User friendly

Simple mounting and setup

Level measurement in a container

After coarse/fine screening, sorted solids such as waste, plastics, sand and sludge are transported to special containers via conveyor belt. Reliable level measurement enables automatic notification to change over these containers.



VEGAPULS C 11

Continuous level measurement with radar in a container

- Maintenance-free operation through non-contact 80 GHz radar technology
- Precise measuring results independent of buildup and condensate
- Highly resistant materials ensure a long service life
- Secure wireless operation via Bluetooth with smartphone, tablet or PC

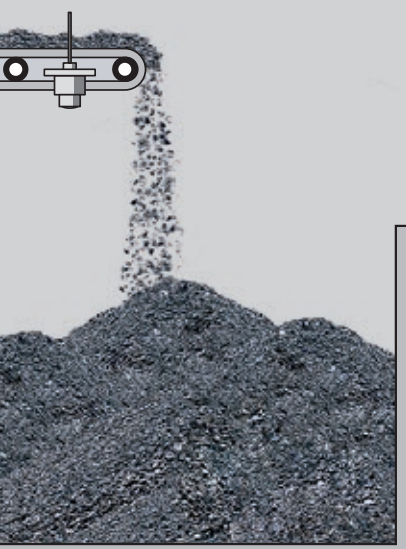



Pump room

Reliable

Reliable protection against flooding due to defective pumps

Cost effective

Simple installation and reliable function

User friendly

Maintenance-free operation

Pressure monitoring and flood protection in the pump room

To protect the process pumps, any leakage water, for example, arising from a faulty pump seal, is detected and an alarm triggered. The pressure in the pipe is measured directly at the pump and displayed in the control system of the plant. Any malfunctions can be quickly detected and dealt with.



VEGASWING 61

Point level detection signals an alarm in case of flooding

- Reliable detection even of small amounts of water
- Adjustment-free and easy to install
- Maintenance-free operation, fail safe design



VEGABAR 82

Process pressure transmitter for monitoring the pump pressure

- High overload resistance, withstands water hammer
- Ceramic measuring cell ensures high long-term stability
- Measurement display directly on the sensor or on the external housing
- Wireless operation via Bluetooth with smartphone, tablet or PC

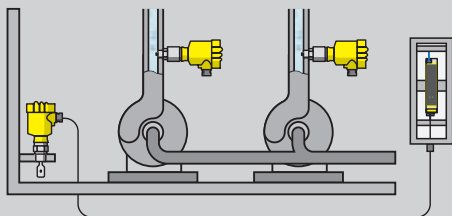

VEGATOR 121

Single channel controller for level detection

- Comprehensive monitoring detects short-circuit and line break of the measuring cable and interferences in the sensor
- Simple and comfortable SIL and WHG function test by means of test key
- Simple installation through carrier rail mounting as well as detachable, coded terminals

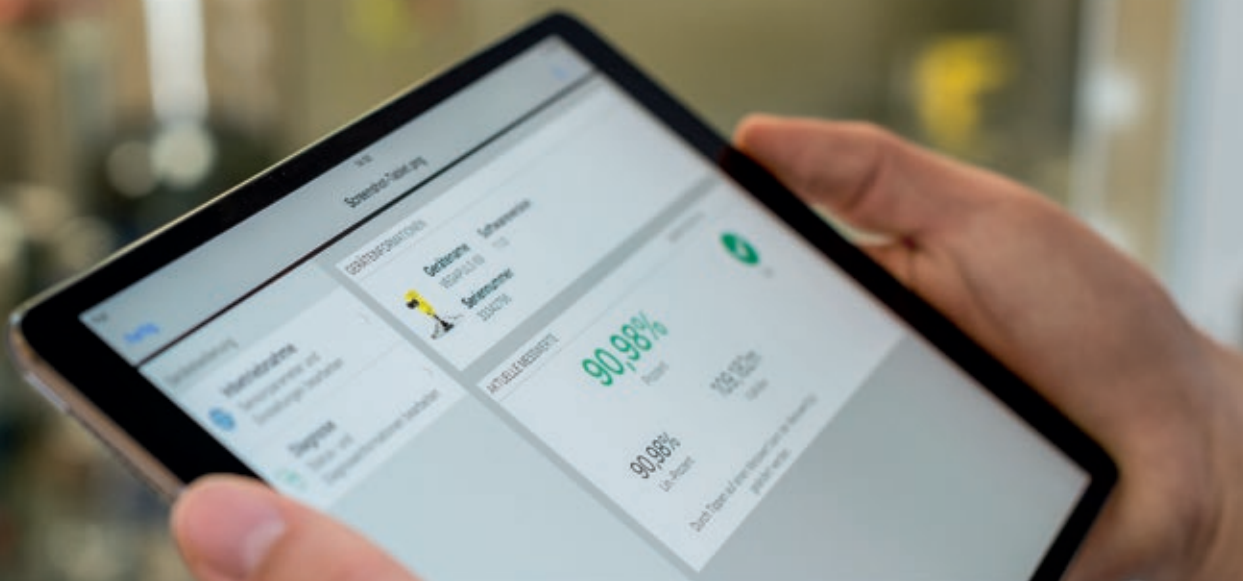

Interconnected solutions



Wireless operation

With Bluetooth, VEGA is looking far into the future. But even today, radio technology is already making processes more and more flexible. Wireless communication provides better accessibility: In clean rooms, in harsh industrial environments and in hazardous areas. It allows setup, display and diagnostics from a distance of up to 25 metres, thus saving time and avoiding hazardous situations. Simply via VEGA Tools app – on any available smartphone or tablet.

myVEGA

With myVEGA as your personal information platform you have access to many useful online functions relating to VEGA products.

- Configurator for the entire VEGA product range
- 2D/3D drawings of configured instruments
- Access to product data, operating instructions, certificates and software
- Manage offers and order data, and also track shipments
- Save, manage and synchronize access codes for VEGA sensors

www.vega.com/myvega

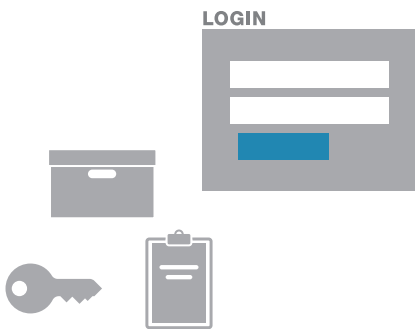



44557-EN-191101

VEGA Grieshaber KG
Am Hohenstein 113
77761 Schiltach
Germany

Phone +49 7836 50-0
E-mail info.de@vega.com
www.vega.com

Looking Forward **VEGA**