



Safety instructions

VEGAPULS 61

Intrinsic safety and flameproof enclosures

PTB 03 ATEX 2163 X

Two-wire 4 ... 20 mA/HART

Four-wire 4 ... 20 mA/HART

Profibus PA

Foundation Fieldbus

HW \geq 2.0.0 - SW \geq 4.0.0



CE 0044



Document ID: 40476



VEGA

Contents

1	Area of applicability.....	4
2	General information.....	4
3	Important specification in the type code.....	4
4	Technical data	6
5	Application conditions	8
6	Protection against static electricity	9
7	Grounding.....	10
8	Impact and friction sparks	10
9	Material resistance	10
10	Mounting with external display unit VEGADIS 61/81.....	10
11	Type of protection flameproof enclosure Ex "db"	11
12	Important information for mounting	12
13	Type and size of the threads of the "Ex-db" cable entries	12
14	Removing and replacing the red threaded/dust cover	13

Supplementary documentation:

- Operating Instructions VEGAPULS 61
- EU-type approval certificate PTB 03 ATEX 2163 X (Document ID: 35321)
- EU declaration of conformity (Document ID: 43634)

Editing status: 2020-11-23

DE	Sicherheitshinweise für den Einsatz in explosionsgefährdeten Bereichen
EN	Safety instructions for the use in hazardous areas
FR	Consignes de sécurité pour une application en atmosphères explosibles
IT	Normative di sicurezza per l'impiego in luoghi con pericolo di esplosione
ES	Instrucciones de seguridad para el empleo en áreas con riesgo de explosión
PT	Normas de segurança para utilização em zonas sujeitas a explosão
NL	Veiligheidsaanwijzingen voor gebruik op plaatsen waar ontploffingsgevaar kan heersen
SV	Säkerhetsanvisningar för användning i explosionsfarliga områden
DA	Sikkerhedsforskrifter til anvendelse i explosionsfarlig atmosfære
FI	Turvallisuusohjeet räjähdysvaarallisissa tiloissa käyttöä varten
EL	Υποδείξεις ασφαλείας για τη χρησιμοποίηση σε περιοχές που υπάρχει κίνδυνος έκρηξης

DE	Die vorliegenden Sicherheitshinweise sind im Download unter www.vega.com standardmäßig in den Sprachen deutsch, englisch, französisch und spanisch verfügbar. Weitere EU-Landessprachen stellt VEGA nach Anforderungen zur Verfügung.
EN	These safety instructions are available as a standard feature in the download area under www.vega.com in the languages German, English, French and Spanish. Further EU languages will be made available by VEGA upon request.
FR	Les présentes consignes de sécurité sont disponibles au téléchargement sous www.vega.com en standard en allemand, en anglais, en français et en espagnol. VEGA met à disposition d'autres langues de l'Union Européenne selon les exigences.
ES	Las indicaciones de seguridad presentes están disponibles en la zona de descarga de www.vega.com de forma estándar en los idiomas inglés, francés y español. VEGA pone a disposición otros idiomas de la UE cuando son requeridos.

1 Area of applicability

These safety instructions apply to the radar sensor VEGAPULS PS61.D****D/H/K/L/P/F/G/M/B/I**** according to EU type approval certificate PTB 03 ATEX 2163 X (certificate number on the type label) and to all instruments with the number of the safety instruction (40476) on the type label.

2 General information

The level measuring instrument VEGAPULS PS61.D****D/H/K/L/P/F/G/M/B/I**** is based on radar technology and is used to detect the distance between medium surface and sensor by means of high frequency electromagnetic waves in the GHz range. The electronics uses the running time of the signals reflected by the medium surface to calculate the distance to the medium surface.

The VEGAPULS PS61.D****D/H/K/L/P/F/G/M/B/I**** consist of an electronics housing with an "Ex-db" connection compartment with integrated two-wire or four-wire barrier and an "Ex-i" connection compartment with integrated electronics module, a process connection element and a sensor, the antenna.

The display and adjustment module PLICSCOM can be optionally integrated in the "Ex-i" connection compartment.

The VEGAPULS PS61.D****D/H/K/L/P/F/G/M/B/I**** are suitable for use in hazardous atmospheres of all combustible materials of explosion group IIA, IIB and IIC for applications requiring instruments of category 1/2G or category 2G.

If the VEGAPULS PS61.D****D/H/K/L/P/F/G/M/B/I**** are installed and operated in hazardous areas, the general Ex installation regulations EN 60079-14 as well as these safety instructions must be observed.

The operating instructions as well as the installation regulations or standards that apply for explosion protection of electrical systems must generally be observed.

The installation of explosion-endangered systems must always be carried out by qualified personnel.

Category 1/2G instruments

The electronics housing is installed in hazardous areas requiring instruments of category 2G. The process connection element is installed in the separating wall, which separates areas requiring instruments of category 2G or 1G. The antenna system with the mechanical fixing element is installed in hazardous areas requiring instruments of category 1G.

Category 2G instruments

The VEGAPULS PS61.D****D/H/K/L/P/F/G/M/B/I**** are installed in hazardous areas requiring an instrument of category 2G.

Type of protection marking:

II 1/2G, II 2G Ex db ia IIC T6 ... T1 Ga/Gb, Gb

3 Important specification in the type code

VEGAPULS PS61(*).abcdefghij

Position		Feature	Description
ab	Approval	DX	ATEX II 1/2G, 2G Ex db ia IIC T6 ... T1 Ga/Gb, Gb
		DA	ATEX II 1/2G, 2G Ex db ia IIC T6 ... T1 Ga/Gb, Gb + WHG
		DM	ATEX II 1/2G, 2G Ex db ia IIC T6 ... T1 Ga/Gb, Gb + Ship approval

Position		Feature	Description
c	Version / Material / Process temperature	A	with encapsulated horn antenna (ø 40 mm) / PVDF / -40 ... +80 °C
		B	with plastic horn antenna (ø 80 mm) / PP / -40 ... +80 °C
de	Process fitting / Material	**	Threaded connection, Clamp, flanges; two-digit alphanumeric code for metallic process fittings, industrial flanges according to ASME, BS, DIN, EN, GOST, HG/T, JIS and for other international, national or industrial standards, guidelines or standards with suitable pressure and temperature specifications
f	Electronics	H	Two-wire 4 ... 20 mA/HART
		D	Two-wire 4 ... 20 mA/HART with increased sensitivity
		B	Four-wire 4 ... 20 mA/HART; 90 ... 253 V AC; 50/60 Hz
		I	Four-wire 4 ... 20 mA/HART; 9.6 ... 48 V DC; 20 ... 42 V AC
		G	Four-wire 4 ... 20 mA/HART with increased sensitivity; 90 ... 253 V AC; 50/60 Hz
		M	Four-wire 4 ... 20 mA/HART with increased sensitivity; 9,6 ... 48 V DC; 20 ... 42 V AC
		P	Two-wire Profibus PA
		K	Two-wire Profibus PA with increased sensitivity
		F	Two-wire Foundation Fieldbus
g	Housing / Protection	L	Two-wire Foundation Fieldbus with increased sensitivity
		D	Aluminium double chamber / IP66/IP68 (0.2 bar)
		S	Special colour Aluminium double chamber / IP66/IP68 (0.2 bar)
		W	Stainless steel double chamber / IP66/IP68 (0.2 bar)
h	Cable entry / Cable gland, Plug connection	M	M20 x 1.5 / without
		N	½ NPT / without
		*	One-digit alphanumeric code for further suitable fittings, cable entries and closing screws.
i	Display and adjustment module PLICSCOM	X	without
		A	mounted
		F	without; lid with inspection window
		K	mounted; with Bluetooth, magnetic pen operation
		U	mounted; with Bluetooth, magnetic pen operation, battery
j	Additional equipment	X	without
		*	with equipment

In the following, all above mentioned versions are called VEGAPULS PS61.D****D/H/K/L/P/F/G/M/B/I****. If parts of these safety instructions refer only to certain versions, then these will be mentioned explicitly with their type code.

4 Technical data

Electrical data

Non-intrinsically safe circuits

VEGAPULS PS61.D**G/M/B/I**** (electronics 4 ... 20 mA/HART - four-wire)**

Power supply: (terminals 1[+], 2[-] in the "Ex-d" connection compartment)	U = 9,6 ... 48 V DC (M/I)
	U = 20 ... 42 V AC (M/I)
	U = 90 ... 250 V AC (G/B)
	Um = 253 V

Active signal circuit: (terminals 5[+], 7[-] in the "Ex-db" connection compartment) I_{out} = 4 ... 20 mA with superimposed HART signal
Um = 60 V

Passive signal circuit: (terminals 6[+], 7[-] in the "Ex-db" connection compartment) I_{in} = 4 ... 20 mA with superimposed HART signal
Um = 60 V

VEGAPULS PS61.D**D/H**** (electronics 4 ... 20 mA/HART - two-wire)**

Power supply and signal circuit: (terminals 1[+], 2[-] in the "Ex-db" connection compartment)	U = 14 ... 36 V DC
	Um = 253 V

VEGAPULS PS61.D**K/L/P/F**** (electronics Profibus PA, Foundation Fieldbus)**

Power supply and signal circuit: (terminals 1[+], 2[-] in the "Ex-db" connection compartment)	U = 14 ... 32 V DC
	Um = 253 V

Intrinsically safe circuits

The connection of these intrinsically safe circuits is carried out on terminals, which are located in an "Ex-i" connection compartment.

VEGAPULS PS61.D****G/M/B/I**** (electronics 4 ... 20 mA/HART - four-wire)

Display and adjustment circuit: (spring contacts in the "Ex i" connection compartment)

Type of protection intrinsic safety Ex ia IIC

Only for connection to the display and adjustment module PLICSCOM or to the VEGA interface converter VEGACONNECT 4 (PTB 07 ATEX 2013 X) or for connection to the intrinsically safe supply and signal circuit of the corresponding external indicating unit VEGADIS 61/81 (PTB 02 ATEX 2136 X) via the VEGADIS-ADAPT.

The rules for the interconnection of intrinsically safe circuits between VEGAPULS PS61.D**** and the external indicating unit VEGADIS 61/81 are fulfilled, provided that the total inductance and total capacitance of the connection cable between VEGAPULS PS61.D**** and the external indicating unit VEGADIS 61/81 $L_{\text{cable}} = 310 \mu\text{H}$ and $C_{\text{cable}} = 2 \mu\text{F}$ are not exceeded.

When using the delivered VEGA connection cable between VEGAPULS PS61.D**** and the external indicating unit VEGADIS 61/81, the following listed cable inductances L_i and cable capacitances C_i must be taken into account with a cable length ≥ 50 m.

- $L_i = 0.62 \mu\text{H/m}$
- $C_{i \text{ wire/wire}} = 132 \text{ pF/m}$
- $C_{i \text{ wire/screen}} = 208 \text{ pF/m}$
- $C_{i \text{ screen/screen}} = 192 \text{ pF/m}$

The intrinsically safe circuits of VEGAPULS PS61.D****G/M/B/I**** are earthed and connected to the external and internal earth terminal.

VEGAPULS PS61.D****D/H/K/L/P/F**** (electronics 4 ... 20 mA/HART - two-wire, Profibus PA, Foundation Fieldbus)

Indicating and adjustment circuit: (terminals 5, 6, 7, 8 in "Ex-i" connection compartment)

Type of protection intrinsic safety Ex ia IIC

For connection to the intrinsically safe circuit of the associated external indicating unit VEGADIS 61/81 (PTB 02 ATEX 2136 X).

The rules for the interconnection of intrinsically safe circuits between VEGAPULS PS61.D**** and the external indicating unit VEGADIS 61/81 are fulfilled, provided that the total inductance and total capacitance of the connection cable between VEGAPULS PS61.D**** and the external indicating unit VEGADIS 61/81 $L_{\text{cable}} = 310 \mu\text{H}$ and $C_{\text{cable}} = 2 \mu\text{F}$ are not exceeded.

When using the delivered VEGA connection cable between VEGAPULS PS61.D**** and the external indicating unit VEGADIS 61/81, the following listed cable inductances L_i and cable capacitances C_i must be taken into account with a cable length ≥ 50 m.

- $L_i = 0.62 \mu\text{H/m}$
- $C_{i \text{ wire/wire}} = 132 \text{ pF/m}$
- $C_{i \text{ wire/screen}} = 208 \text{ pF/m}$
- $C_{i \text{ screen/screen}} = 192 \text{ pF/m}$

Display and adjustment circuit: (spring contacts in the "Ex i" connection compartment)

In type of protection intrinsic safety Ex ia IIC
 Only for connection to the intrinsically safe signal circuit of a VEGA interface converter VEGACONNECT 4 (PTB 07 ATEX 2013 X) or the display and adjustment module PLICSCOM.

The intrinsically safe circuits of VEGAPULS PS61.D****D/H/K/L/P/F**** are potential free and reliably galvanically separated from the non-intrinsically safe circuit up to a peak value of the voltage of 375 V.

The metallic parts of VEGAPULS PS61.D*** are electrically connected with the earth terminals.

5 Application conditions

The max. permissible ambient temperatures depending on the temperature classes are specified in the following tables.

VEGAPULS PS61.D**D/H/G/M/B/I**** (electronics 4 ... 20 mA/HART - two-wire, 4 ... 20 mA/HART - four-wire)**

Category 1/2G instruments

Temperature class	Temperature on the sensor	Ambient temperature on the electronics
T6	-20 ... +60 °C	-40 ... +46 °C
T5, T4, T3, T2, T1	-20 ... +60 °C	-40 ... +60 °C

For applications requiring instruments of category 1/2G the process pressure of the media must be between 0.8 ... 1.1 bar. If the sensors VEGAPULS PS61.D****D/H/G/M/B/I**** are operated at temperatures higher than those specified in the above table, please make sure by means of appropriate measures that there is no danger of ignition from the hot surfaces. The max. permissible temperature on the electronics/housing should not exceed the values according to the above table.

Please make sure that the sensor also in case of failure does not generate heat itself. Responsibility for safe operation of the equipment, with respect to pressures/temperatures of the materials used, rests with the operator.

The prerequisites for operation in the absence of explosive mixtures can be found in the manufacturer specifications.

Category 2G instruments

Temperature class	Temperature on the sensor	Ambient temperature on the electronics
T6	-60 ... +80 °C	-40 ... +46 °C
T5	-60 ... +80 °C	-40 ... +60 °C
T4	-60 ... +80 °C	-40 ... +60 °C
T3	-60 ... +80 °C	-40 ... +60 °C
T2	-60 ... +80 °C	-40 ... +60 °C
T1	-60 ... +80 °C	-40 ... +60 °C

If the sensors of VEGAPULS PS61.D****D/H/G/M/B/I**** are operated at higher temperatures than those specified in the above table, please make sure by means of appropriate measures that there is no danger of ignition from hot surfaces. The permissible temperature on the electronics/housing

must not exceed the values specified in the above table.

Please make sure that the sensor also in case of failure does not generate heat itself. Responsibility for safe operation of the equipment, with respect to pressures/temperatures of the materials used, rests with the operator.

The prerequisites for operation in the absence of explosive mixtures can be found in the manufacturer specifications.

VEGAPULS PS61.D****K/L/P/F**** (electronics Profibus PA, Foundation Fieldbus)

Category 1/2G instruments

Temperature class	Temperature on the sensor	Ambient temperature on the electronics
T6	-20 ... +60 °C	-40 ... +46 °C
T5, T4, T3, T2, T1	-20 ... +60 °C	-40 ... +60 °C

For applications requiring instruments of category 1/2G the process pressure of the media must be between 0.8 ... 1.1 bar. If the sensors VEGAPULS PS61.D****K/L/P/F**** are operated at temperatures higher than those specified in the above table, please make sure by means of appropriate measures that there is no danger of ignition from the hot surfaces. The max. permissible temperature on the electronics/housing should not exceed the values according to the above table.

Please make sure that the sensor also in case of failure does not generate heat itself. Responsibility for safe operation of the equipment, with respect to pressures/temperatures of the materials used, rests with the operator.

The prerequisites for operation in the absence of explosive mixtures can be found in the manufacturer specifications.

Category 2G instruments

Temperature class	Temperature on the sensor	Ambient temperature on the electronics
T6	-60 ... +80 °C	-40 ... +46 °C
T5	-60 ... +80 °C	-40 ... +60 °C
T4	-60 ... +80 °C	-40 ... +60 °C
T3	-60 ... +80 °C	-40 ... +60 °C
T2	-60 ... +80 °C	-40 ... +60 °C
T1	-60 ... +80 °C	-40 ... +60 °C

If the sensors of VEGAPULS PS61.D****K/L/P/F**** are operated at higher temperatures than those specified in the above table, please make sure by means of appropriate measures that there is no danger of ignition from hot surfaces. The permissible temperature on the electronics/housing must not exceed the values specified in the above table.

Please make sure that the sensor also in case of failure does not generate heat itself. Responsibility for safe operation of the equipment, with respect to pressures/temperatures of the materials used, rests with the operator.

The prerequisites for operation in the absence of explosive mixtures can be found in the manufacturer specifications.

6 Protection against static electricity

The VEGAPULS PS61.D****D/H/K/L/P/F/G/M/B/I**** in versions with electrostatically chargeable

plastic parts, lacquered housing, metal housing with inspection window or plastic antenna, have a caution label pointing out the safety measures that must be taken with regard to electrostatic charges during operation.

WARNING - POTENTIAL ELECTROSTATIC
CHARGING HAZARD - SEE INSTRUCTIONS

Caution: Plastic parts! Danger of electrostatic charging!

- Avoid friction
- No dry cleaning
- Construction/Installation: The VEGAPULS PS61.D****D/H/K/L/P/F/G/M/B/I**** must be constructed/installed in such a way that
 - electrostatic charges are ruled out during operation, maintenance and cleaning.
 - process-related electrostatic charges, e.g. by measuring media flowing past, are ruled out

7 Grounding

Do avoid danger of electrostatic charge of the metal parts, the VEGAPULS PS61.D****D/H/K/L/P/F/G/M/B/I**** must be generally connected to the local potential equalization, e.g. via the earth terminal.

The pressure-resistant connection compartment of VEGAPULS PS61.D****G/M/B/I**** includes also a safety barrier without galvanic separation. For safety reasons, the intrinsically safe circuit must be earthed. The external or internal earth connection terminal on the housing serves for this purpose.

The pressure-resistant connection compartment of VEGAPULS PS61.D****D/H/K/L/P/F**** includes also a safety barrier with galvanic separation. The intrinsically safe circuit should be set up ungrounded. The necessary isolating voltage is ≥ 375 V AC. When using the supplied VEGA connection cable, this requirement is fulfilled.

Metallic adapter flanges must be earthed, especially when installed on non-conductive plastic vessels or non-earthed vessels. Earthing can be realised with cable lug via the flange gland.

8 Impact and friction sparks

The VEGAPULS PS61.D****D/H/K/L/P/F/G/M/B/I**** in aluminium version must be mounted in such a way that sparks from impact and friction between aluminium and steel (except stainless steel, if the presence of rust particles can be excluded) cannot occur.

The VEGAPULS PS61.D****D/H/K/L/P/F/G/M/B/I**** in the titanium versions must be mounted in such a way that sparks from impact and friction between titanium and any other hard material cannot occur.

9 Material resistance

With applications requiring instruments of category 1/2G the VEGAPULS PS61.D****D/H/K/L/P/F/G/M/B/I**** should only be used in media against which the wetted materials are sufficiently resistant.

10 Mounting with external display unit VEGADIS 61/81

The intrinsically safe signal circuit between VEGAPULS PS61.D****D/H/K/L/P/F/G/M/B/I**** and the external indicating unit VEGADIS 61/81 should be set up without grounding. The required insulation voltage is > 500 V AC. When using the VEGA connection cable included with the delivery, this requirement is fulfilled. If grounding of the cable screen is required, it must be carried out according to EN 60079-14.

11 Type of protection flameproof enclosure Ex "db"

The terminals for connecting the operating voltage or signal circuits are integrated in the connection compartment with type of protection flameproof enclosure "db".

The thread gaps between housing and cover as well as between threaded fitting and container are flameproof joints.

The "Ex-db" connection compartment is provided with a M20 x 1.5 or 1/2-14 NPT thread for connection to a certified "Conduit" system or for mounting a "Ex-db" cable entry certified according to EN 60079-1. Cable entries of simple construction may not be used. Please take note of section 13.1 and 13.2 of EN 60079-1. When connecting to a "Conduit" system, the associated sealing facility must be located directly on the "Ex-db" connection compartment.

A certified "Ex-d" cable gland can optionally be supplied with the delivery. It is suitable for insertion of armoured or unarmoured cables depending on the ordered version. The instructions in the document accompanying the respective cable entry must be observed. The "Ex-db" cable entry must be screwed tightly into the housing. The supplied cable entry is suitable for the housing temperature range mentioned in the VEGAPULS PS61.D****D/H/K/L/P/F/G/M/B/I**** specification. If a different cable entry is used, the separately certified cable entry or the temperature classes on the electronics determines the maximum permissible ambient temperature on the housing.

Before opening the lid of the "Ex-db" terminal compartment or in case it is already open (e. g. during connection or service work), make sure that either the supply cable is completely voltage free or no explosive atmosphere is present.

When wiring the connection line to the "Ex-db" connection compartment, it must be sufficiently secured against damage and in conformity with EN 60079-14.

The connection cables, the cable entries and the plugs or the pipeline sealing facilities must be suitable for the application conditions (e.g. temperature range).

The cover of the "Ex-db" connection compartment must be screwed in completely before commissioning and secured by screwing out the lid locking screw all the way to the stop.

Unused openings must be sealed according to EN 60079-1 paragraph 11.9.

The flame path joints must not be repaired.

Double chamber housing with "Ex-db" connection compartment



- 1 "Ex-i" connection compartment with electronics module
- 2 Locking screw of the lid
- 3 "Ex db" connection compartment with integrated barrier
- 4 Screw plug

The cover of the "Ex-db" connection compartment with the caution label "Do not open when an explosive atmosphere is present" and the cover of the "Ex-i" connection compartment without caution label must not be exchanged. The covers must be mounted on the corresponding connection compartments.

12 Important information for mounting

Cable glands, threaded openings

Type	Thread	Cable diameter [mm]	Torques [Nm]
Hummel EXIOS A2F 1.608.2003.50	M20 x 1.5	6 ... 12 mm	8
Hummel EXIOS A2F 1.608.1203.70	½ NPT	6 ... 12 mm	8
Hummel EXIOS MZ 1.6Z5.2000.51	M20 x 1.5	9 ... 13 mm	8
Hummel EXIOS MZ 1.6Z5.1200.70	½ NPT	9 ... 13 mm	8

The specified torques are test torques and can only be regarded as reference values. The manufacturer's mounting instructions provided must be observed.

If suitable cable glands or cable insertion possibilities not included in the scope of supply are used, these must be compatible with the threaded openings.

Aluminium housing with M20 x 1.5 thread, ½ NPT thread

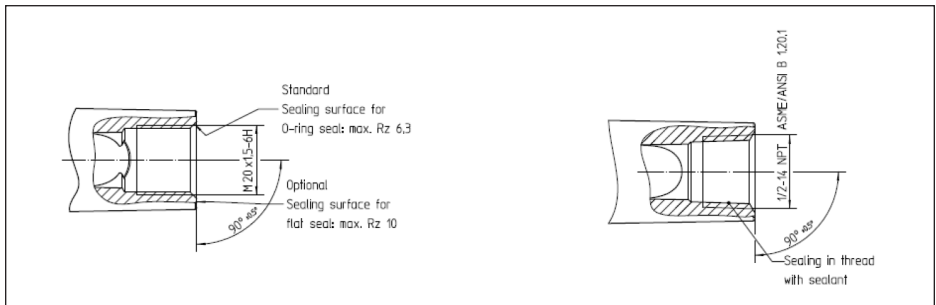

Stainless-steel housing (fine cast) with M20 x 1.5 thread, ½ NPT thread

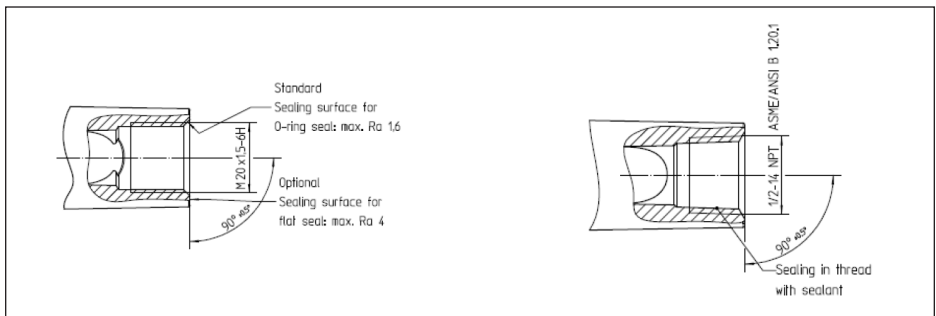

13 Type and size of the threads of the "Ex-db" cable entries

The "Ex-db" connection compartment of VEGAPULS PS61.D****D/H/K/L/P/F/G/M/B/I*M** has

cable entries M20 x 1.5.

The "Ex-db" connection compartment of VEGAPULS PS61.D****D/H/K/L/P/F/G/M/B/I*N** has cable entries ½-14 NPT.

14 Removing and replacing the red threaded/dust cover

When the VEGAPULS PS61.D****D/H/K/L/P/F/G/M/B/I**** are delivered, depending on the version, the red threaded or dust protection caps must be removed before installing the device and the openings must be sealed according to the requirements of the type of protection and the IP protection type specified on the type label.

When using certified i.e. suitable cable glands, sealing plugs or plug connectors, they must be mounted correctly and the respective certificates/documents must be observed.

The sealing plugs included in the delivery by VEGA meet the necessary requirements.

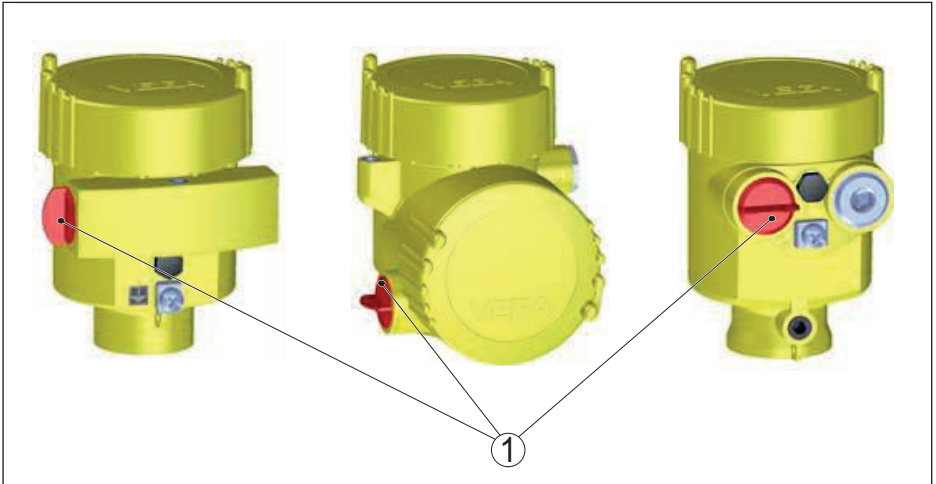

1 Red threaded or dust protection cap

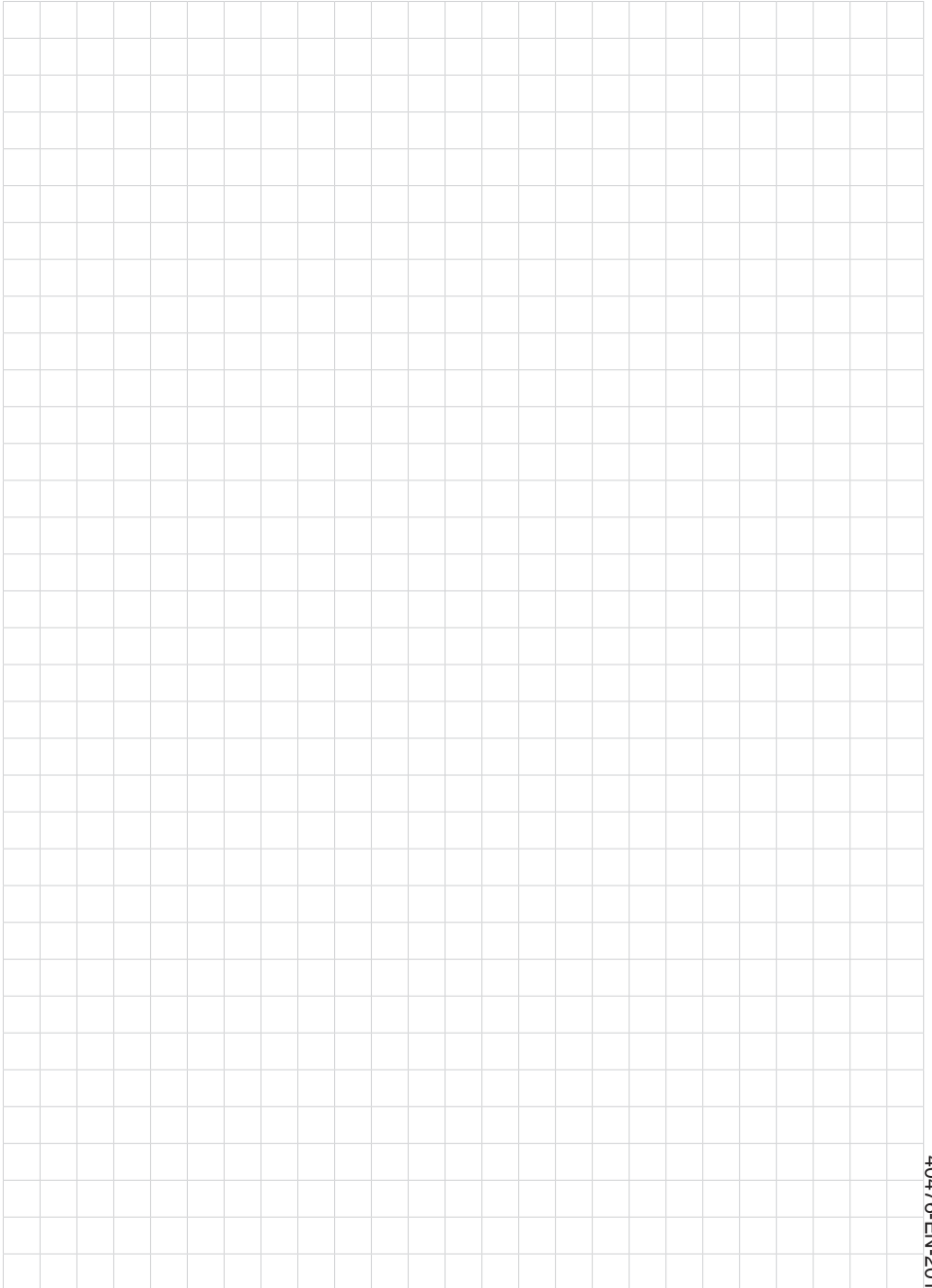



Printing date:

VEGA

All statements concerning scope of delivery, application, practical use and operating conditions of the sensors and processing systems correspond to the information available at the time of printing.

Subject to change without prior notice

© VEGA Grieshaber KG, Schiltach/Germany 2020



40476-EN-201202

VEGA Grieshaber KG
Am Hohenstein 113
77761 Schiltach
Germany

Phone +49 7836 50-0
Fax +49 7836 50-201
E-mail: info.de@vega.com
www.vega.com